

Paragraph	page	
1.0 Receiving instructions.....	2	9.0 Dismantling the ATM-4 .....
2.0 Safety Issues.....	2	10.0 Inspection and Examination.....
3.0 Product Description .....	2	11.0 Storage.....
4.0 Safety Information - ATM-4 .....	3	12.0 Lubrication and Maintenance .....
5.0 Misalignment Determination Procedure .....	3	13.0 Troubleshooting .....
6.0 Installation and Operation.....	4	14.0 Application Dimensions .....
7.0 Rotational or Twist Misalignment .....	5	15.0 Range of Application Tables.....
8.0 Vertical Operation .....	6	16.0 Weights and Dimensions .....

For other languages go to [www.enerpac.com](http://www.enerpac.com).

Weitere Sprachen finden Sie unter [www.enerpac.com](http://www.enerpac.com).

Para otros idiomas visite [www.enerpac.com](http://www.enerpac.com).

Pour toutes les autres langues, rendez-vous sur [www.enerpac.com](http://www.enerpac.com).

Per altre lingue visitate il sito [www.enerpac.com](http://www.enerpac.com).

その他の言語は[www.enerpac.com](http://www.enerpac.com)でご覧いただけます。

이 지침 시트의 다른 언어 버전은 [www.enerpac.com](http://www.enerpac.com).

Ga voor de overige talen naar [www.enerpac.com](http://www.enerpac.com).

For alle andre språk henviser vi til [www.enerpac.com](http://www.enerpac.com).

Para outros idiomas consulte [www.enerpac.com](http://www.enerpac.com).

如需其他语言, 请前往 [www.enerpac.com](http://www.enerpac.com).

## 1.0 RECEIVING INSTRUCTIONS

Visually inspect all components for shipping damage. Shipping damage is not covered by warranty. If shipping damage is found notify carrier at once. The carrier is responsible for all repair and replacement costs resulting from damage in shipment.

### SAFETY FIRST

Read all instructions, warnings and cautions carefully. Follow all safety precautions to avoid personal injury or property damage during system operation. Enerpac cannot be responsible for damage or injury resulting from unsafe product use, lack of maintenance or incorrect product and/or system operation. Contact Enerpac when in doubt as to the safety precautions and applications.

A **CAUTION** is used to indicate correct operating or maintenance procedures and practices to prevent damage to, or destruction of equipment or other property

A **WARNING** indicates a potential danger that requires correct procedures or practices to avoid personal injury.

## 2.0 SAFETY ISSUES



Failure to comply with the following cautions and warnings could cause equipment damage and personal injury.



**IMPORTANT:** Minimum age of the operator must be 18 years. The operator must have read and understood all instructions, safety issues, cautions and warnings before starting to operate the Enerpac equipment. The operator is responsible for this activity towards other persons.



**CAUTION:** Make sure that all system components are protected from external sources of damage, such as excessive heat, flame, moving machine parts, sharp edges and corrosive chemicals.



**WARNING:** Immediately replace worn or damaged parts with genuine Enerpac parts. Enerpac parts are designed to fit properly and withstand rated loads.



**WARNING:** Always wear safety glasses. The operator must take precaution against injury due to failure of the tool or workpiece



We recommend the use of special loosening liquids or sprays. Enerpac hydraulic torque wrenches offer both square and hexagon drive units to loosen or tighten bolts and nuts. Enerpac offers nut splitters in case a nut can not be removed.

## 3.0 PRODUCT DESCRIPTION

The ATM-4 Alignment Tool is intended for use in typical maintenance and installation procedures. It allows the realignment of misaligned flanges within a 4 ton [40 kN] physical capacity. It may be used to assist in the replacement of ring and other type joints.

The use of these instructions will promote the safe use and maximum service life of the tool. All sections of this instruction sheet should be read prior to using the tool.

### 3.1 Applications

The ATM-4 Alignment Tool can be used for: Flange change outs, repair of pipe lines, replacing bolts, gaskets and seals and for aligning parts for fabricating.

### 3.2 Major Features and Components

See Fig. 1. for an overview of ATM-4 major features and components.

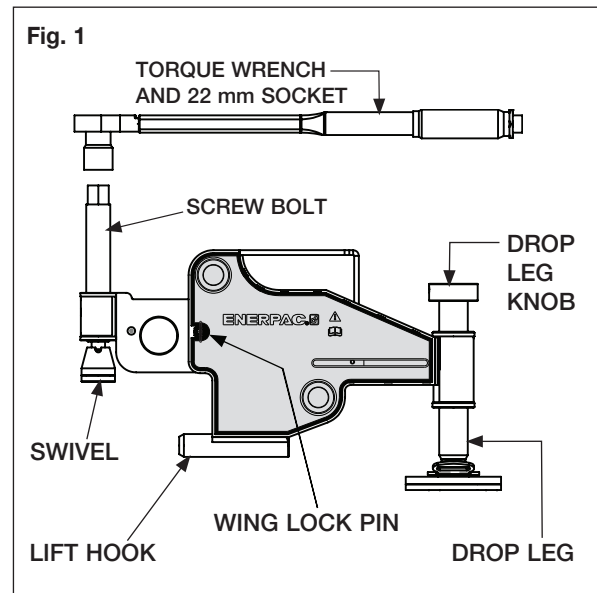

### 3.3 Capacity Information

Maximum Load	
Wing Fully Retracted:	Wing Fully Extended:
3.0 T [30 kN] from 50 ft-lbs [68 Nm] of torque.	4.0 T [40 kN] from 50 ft-lbs [68 Nm] of torque.

#### 4.0 SAFETY INFORMATION - ATM-4

**IMPORTANT:** In all installations the site safety requirements must be adhered to and that safety of the operator and, when present, any assisting personnel is of paramount importance along with the safety of others including, when present, the general public.

These instructions are only to cover the safe operation of ATM-4 during a normal maintenance / installation operation. All other safety aspects must be controlled by the operation supervisor.



**CAUTION:** The ATM-4 must not be attached to pressure vessel nozzles.



**WARNING:** Never attach the ATM-4 to a joint until after the flange bolts have been loosened and removed. Overloading may occur if bolts are removed while the tool is installed, and the resulting force is greater than the safe working load of the tool.

#### 5.0 MISALIGNMENT DETERMINATION PROCEDURE

- The ATM-4 **MUST NOT** be attached to a flanged joint prior to the misalignment determination procedure being carried out. Refer to warning statement in section 4.0.
- Every second bolt should be loosened and removed around the flange. Continue with this procedure. Misalignment may not occur until only a few bolts remain. At this point the direction of any misalignment should become obvious.
- The ATM-4, once attached, will directly push against the misalignment, bringing the joint back into alignment.

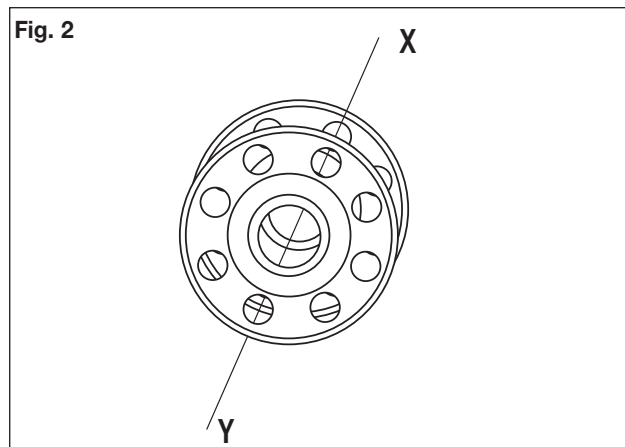

The ATM-4 should be attached at the maximum point of misalignment.

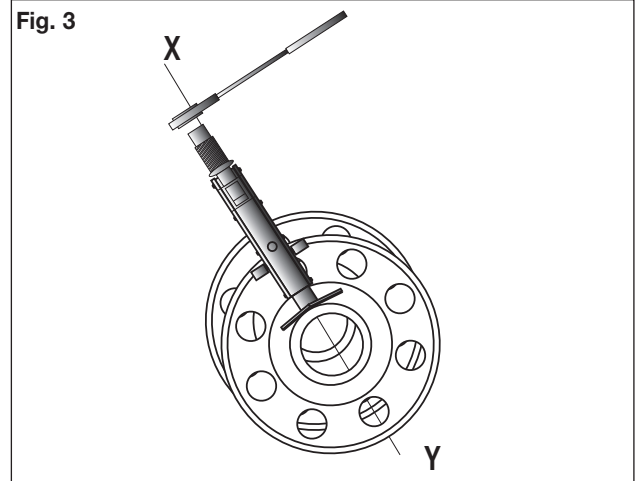

The point of attachment is determined by the direction of misalignment at its maximum point, i.e., X or Y.

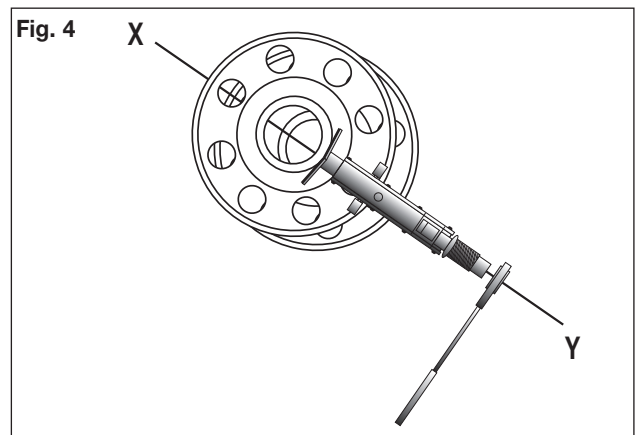

Each of the examples here show where the ATM-4 should be attached.

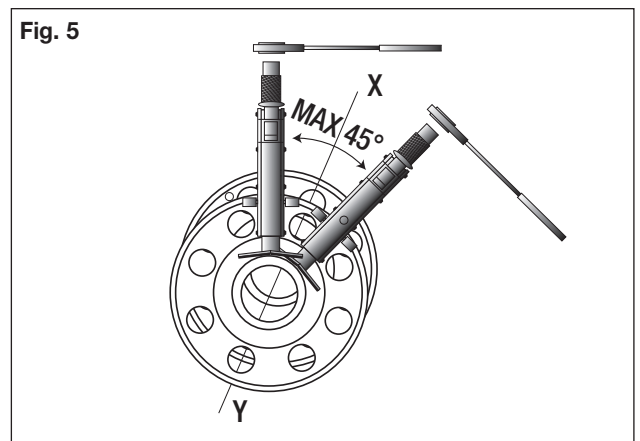

If for some reason attachment at X,Y is obstructed, two ATM-4's can be used as illustrated. (see Fig. 5) but must not be placed more than 45° apart.

## 6.0 INSTALLATION AND OPERATION

Fig. 6

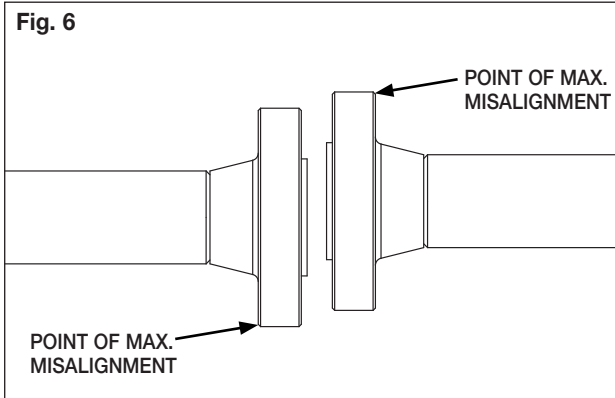

1. Determine the maximum points of misalignment. In the example shown in Fig. 6 example, the maximum points are on the top or bottom of the joint, as illustrated by the arrows.
2. Guide the lift hook of the tool into the bolt hole at the maximum point of misalignment. Then, adjust the drop leg down onto the pipe by turning the adjusting knob in the clockwise direction (see Fig. 7).

Fig. 7

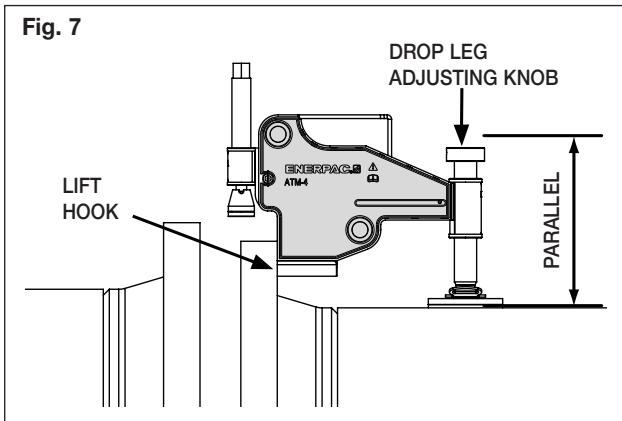

**Note:** The tool should be held up level within the bolt hole during adjustment. The tool must remain parallel to the pipe at all times.

Fig. 8

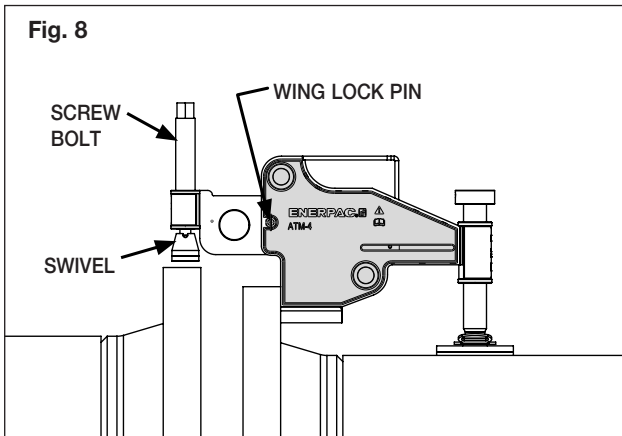

3. Pull out the wing lock pin and extend the wing over to the opposite flange. Then, rotate the screw bolt onto the surface of the opposite flange (See Fig. 8).

Ensure that tool is sitting level and that the friction pad on the base of the swivel is in full and even contact with the surface of the opposite flange.

Fig. 9

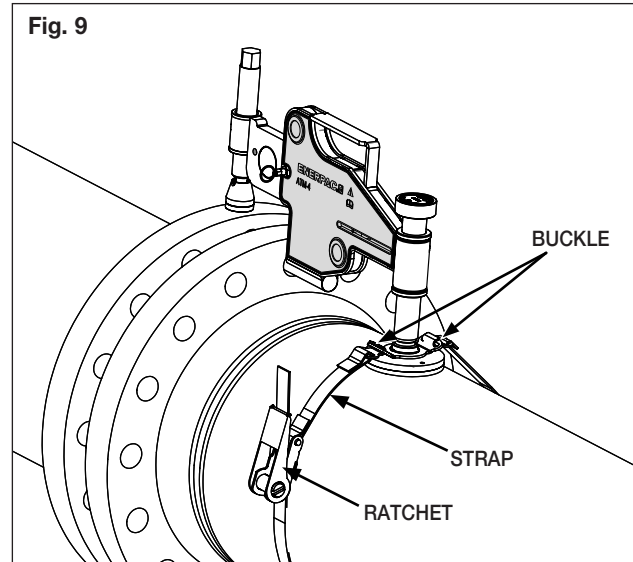

4. Attach the hook of the strap through one of the slots on the buckle (located above the drop leg pad). Place the hook of the ratchet through the other slot on the opposite side of the buckle. Feed the end of the strap through the ratchet and tighten. (see Fig. 9).

Fig. 10

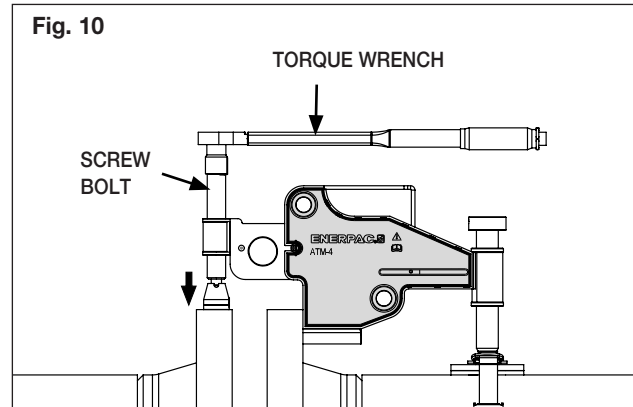

5. Using the supplied torque wrench and 22 mm socket, tighten the screw bolt in a clockwise direction until the flanges come into alignment, and bolts can be inserted. (see Fig. 10).

**Note:** The torque wrench and 22 mm socket supplied with the tool is preset to apply a maximum force of 50 ft. lbs. [68 Nm].



**CAUTION:** Only use torque wrench supplied with ATM-4.



**CAUTION: Do not exceed maximum force rating.** Maximum force on screw bolt is 50 ft. lbs. [68 Nm]. Damage to tool will result if maximum force rating is exceeded.



**CAUTION: Do not use impact tool on screw bolt.** Severe damage to the tool will result if impact tool is used.

## 7.0 ROTATIONAL OR TWIST MISALIGNMENT

This is a common problem on both onshore and offshore pipeline installations (see Fig. 11). Quite often the flanges are in alignment but the operator is unable to fit the bolt into any two corresponding bolt holes on the joint's circumference.

Fig. 11

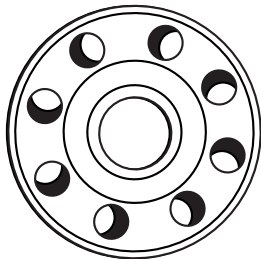

Rotational or Twist Misalignment

The ATM-4, within its 4 Ton [40 kN] maximum capacity, has the ability to manipulate the flanges in various directions. The setting-up procedure is the same as before with one possible exception. The ATM-4 can be attached to the most accessible point on the joint's circumference because the misalignment occurs at all bolt-holes to the same degree.

The recommended operating procedures are:

1. Select the most convenient or accessible point on the joint's circumference and attach the tool there. (Follow steps 1 thru 4 in paragraph 6.0)

Fig. 12

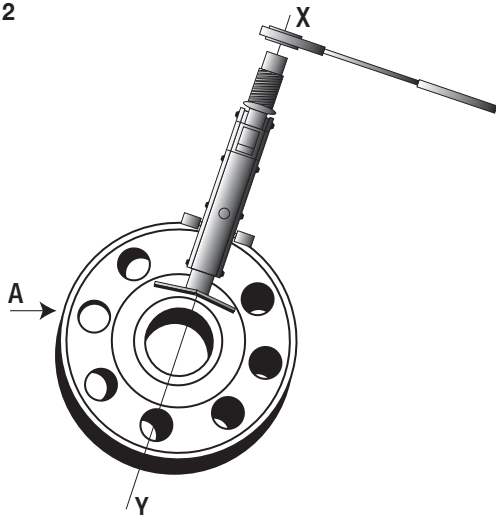

2. In this situation when both flanges are aligned but rotational misalignment is present, the ATM-4 is used to push the flanges out of alignment until one pair of bolt holes become parallel (see point A, Fig. 12).

Fig. 13

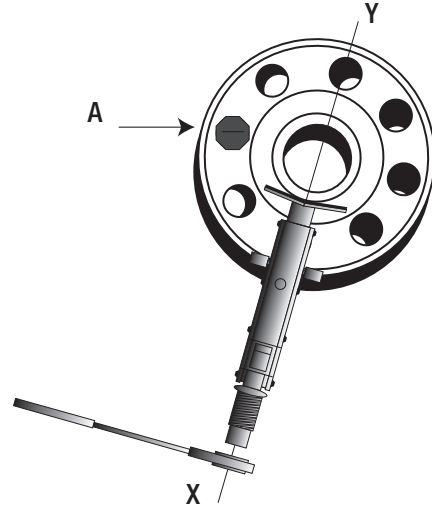

3. Insert the bolt into the bolt-hole at Point A (see Fig. 13) and then release the ATM-4. The load will transfer onto the inserted bolt.
4. The ATM-4 can then be attached at another point on the joint's circumference (see Fig. 14) pushing against the inserted bolt. Advance the screw bolt until another, or all of the bolt-holes are parallel. Once the remaining bolts are inserted, the ATM-4 can be removed.

Fig. 14

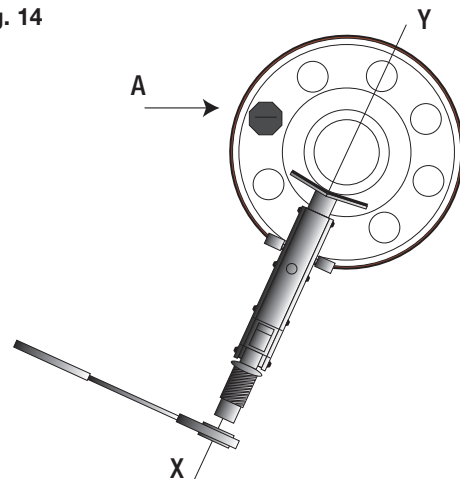

Please note that in some situations the operator may have to 'chase' the misalignment around the joint's circumference and attach the ATM-4 at several different positions to rectify the misalignment. On each occasion the procedures outlined in steps 1 to 5 in paragraph 6.0 should be followed.

## 8.0 VERTICAL OPERATION

The set-up and operation of ATM-4 in the vertical position remains the same as steps 1 thru 5 in section 6.0 (see Fig. 15).

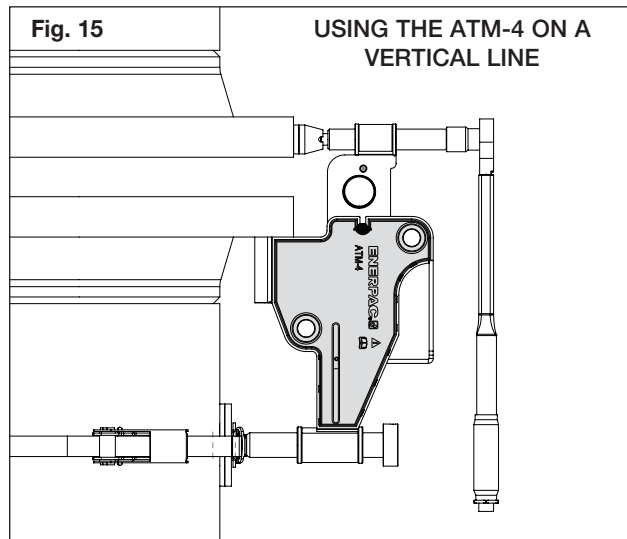

## 9.0 DISMANTLING THE ATM-4

- Once alignment is achieved, all work on the joint finished, and bolt-up completed (apart from the bolt hole in which the ATM-4 is housed), the tool can be dismantled by reversing steps 1 thru 5 in paragraph 6.0.
- Care should be taken not to drop any of the component parts when removing them from the aligned joint. This action will prevent injuries to either the operator's lower limbs, or to passers-by.

## 10.0 INSPECTION AND EXAMINATION

- After finishing the job and before the ATM-4 is placed back into service, the completeness of the tool must be established and items examined to ensure that they are serviceable.
- Any missing or damaged items are to be replaced as soon as possible and prior to the tool being used again.
- Grease all moving parts regularly Refer to section 12.0, Lubrication and Maintenance.
- Ensure rollers and pins remain grit free.
- Return all items to the carrying case when not in use.

## 11.0 STORAGE

- The ATM-4 should be stored in a cool dry place.
- Machined surfaces are to be smeared with Mobilgrease XHP™ 222 Special grease or an equivalent good quality high load bearing grease.

## 12.0 LUBRICATION AND MAINTENANCE

Use Mobilgrease XHP™ 222 Special grease or an equivalent good quality high load bearing grease.

### Maintaining the Tool

Always ensure the screw bolt is lubricated before use. This will enhance the tool's performance and lifetime.

On the base of the screw bolt within the swivel is housed a thrust bearing which should be free running and lubricated regularly.

Set the torque wrench to the lowest setting after each use and for storage.

### Cleaning and lubrication of internal parts (see Fig. 16)

- STEP 1. Place tool upright on a work bench.
- STEP 2. Using a flat blade screwdriver, lever out the end of each spiral clip. Then, rotate them counter clockwise to remove.
- STEP 3. Slide the roller shafts out in order to remove the rollers and bearings for examination.
- STEP 4. Inspect the roller shafts, rollers and bearings for damage. If there is no damage present, they can then be cleaned, greased and reassembled (reverse steps 1 through 3).

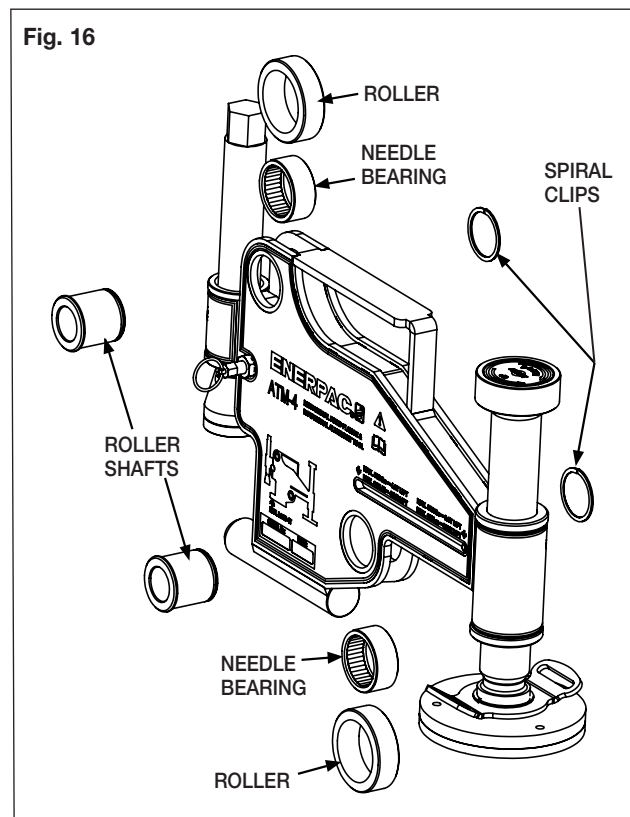



### 13.0 TROUBLESHOOTING

**PROBLEM 1:** THE SCREW BOLT FEELS TIGHT TO ROTATE.

**SOLUTION:** Ensure there is grease present on screw bolt.

**PROBLEM 2:** THE FRICTION PAD ON THE SWIVEL, AT THE BASE OF THE SCREW BOLT, IS ROTATING ON THE FLANGE CIRCUMFERENCE.

**Note:** The tool should not be used if the friction pad is rotating on the flange circumference.

**CAUSE:** The swivel bearing is dirty or seized.

**SOLUTION:** The swivel should be stripped down, cleaned, greased and reassembled. If the problem still occurs replace the swivel assembly (see repair parts sheet).

**PROBLEM 3:** THE FRICTION PAD IS SLIDING ON THE FLANGE CIRCUMFERENCE AS THE JOINT IS ALIGNING.

**CAUSE:** Grit or dirt on wing, roller bearings require greasing. The tool has reached full extension.

**SOLUTION:** Ensure the rollers are rotating freely on the wing of the tool as it extends out. If they are not, strip tool, clean and grease rollers and wing. (see paragraph 12.0, Lubrication and Maintenance).

If tool has reached full extension, the joint will most likely be outside of the ATM-4 range.

**PROBLEM 4:** THE TOOL IS ATTACHED AND APPEARS TO BE FUNCTIONING PROPERLY, BUT THE JOINT WILL NOT ALIGN.

**CAUSE:** Hidden obstruction on the joint or surrounding pipe, the load required to align the joint is greater than that of the ATM-4 (i.e. 4 Ton [40 kN]).

**SOLUTION:**

- Check the area around the joint for obstructions.
- It may be that the required pressure to align the joint is greater than the 4 ton [40 kN] capacity of the tool. In this instance another method to align the joint should be adopted.

### 14.0 APPLICATION DIMENSIONS

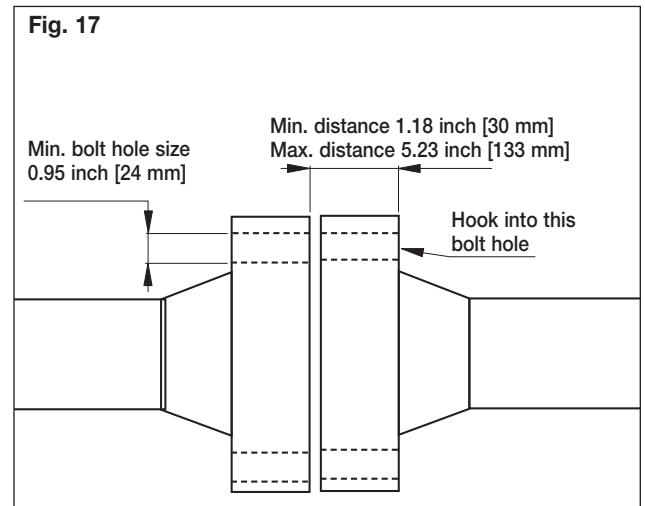

## 15.0 RANGE OF APPLICATION TABLES

### 15.1 BS10 Flange Range of Application

CLASS A	NPS	3 1/2"	4"	5"	6"	7"	8"	9"	10"	12"	13"	14"	15"	16"	17"	18"	19"	20"	21"	22"	23"	24"	26"	27"	29"	30"	33"	35"	36"	39"	42"	45"	48"	54"	60"	66"	72"			
	TOOL	ATM-2																																						
CLASS D	NPS	4"	5"	6"	7"	8"	9"	10"	12"	13"	14"	15"	16"	17"	18"	19"	20"	21"	22"	23"	24"	29"	30"	33"	35"	36"	39"	42"	45"	48"	54"	60"	66"	72"	78"	84"	96"	108"	120"	
	TOOL	ATM-4																																						
CLASS E	NPS	1 1/4"	2"	2 1/2"	3"	3 1/2"	4"	5"	6"	7"	8"	9"	10"	10"	12"	13"	14"	15"	16"	17"	18"	19"	20"	21"	22"	23"	24"	27"	29"	30"	33"	35"	36"	39"	42"	45"	48"			
	TOOL	ATM-2																																						
CLASS F	NPS	1 1/4"	1 1/2"	2"	2 1/2"	3"	3 1/2"	4"	5"	6"	7"	8"	9"	10"	10"	12"	13"	14"	15"	16"	17"	18"	19"	20"	21"	22"	23"	24"	27"	29"	30"	33"	35"	36"	39"	42"	45"	48"		
	TOOL	ATM-4																																						
CLASS H	NPS	1 1/4"	2"	2 1/2"	3"	3 1/2"	4"	5"	6"	7"	8"	9"	10"	10"	12"	13"	14"	15"	16"	17"	18"	19"	20"	21"	22"	23"	24"	27"	29"	30"	33"	35"	36"	39"	42"	45"	48"			
	TOOL	ATM-4																																						
CLASS J	NPS	1 1/4"	2"	2 1/2"	3"	3 1/2"	4"	5"	6"	7"	8"	9"	10"	10"	12"	13"	14"	15"	16"	17"	18"	19"	20"	21"	22"	23"	24"	27"	29"	30"	33"	35"	36"	39"	42"	45"	48"			
	TOOL	ATM-2																																						
CLASS K	NPS	1"	1 1/4"	2"	2 1/2"	3"	3 1/2"	4"	5"	6"	7"	8"	9"	10"	10"	12"	13"	14"	15"	16"	17"	18"	19"	20"	21"	22"	23"	24"	27"	29"	30"	33"	35"	36"	39"	42"	45"	48"		
	TOOL	ATM-2																																						
CLASS R	NPS	1"	1 1/4"	2"	2 1/2"	3"	3 1/2"	4"	5"	6"	7"	8"	9"	10"	10"	12"	13"	14"	15"	16"	17"	18"	19"	20"	21"	22"	23"	24"	27"	29"	30"	33"	35"	36"	39"	42"	45"	48"		
	TOOL	ATM-4																																						
CLASS S	NPS	1/2"	3/4"	1"	1 1/4"	2"	2 1/2"	3"	3 1/2"	4"	5"	6"	7"	8"	9"	10"	11"	12"	13"	14"	15"	16"	17"	18"	19"	20"	21"	22"	23"	24"	27"	29"	30"	33"	35"	36"	39"	42"	45"	48"
	TOOL	ATM-2																																						
CLASS T	NPS	1/2"	3/4"	1"	1 1/4"	2"	2 1/2"	3"	3 1/2"	4"	5"	6"	7"	8"	9"	10"	11"	12"	13"	14"	15"	16"	17"	18"	19"	20"	21"	22"	23"	24"	27"	29"	30"	33"	35"	36"	39"	42"	45"	48"
	TOOL	ATM-2																																						

SUITABLE FOR ENERPAC ATM-2 TOOL
SUITABLE FOR ENERPAC ATM-4 TOOL
SUITABLE FOR ENERPAC ATM-9 TOOL
NOT SUITABLE FOR ANY ENERPAC ATM TOOL

Note: Models ATM-2 and ATM-9 shown for reference purposes only.

### 15.2 API6BX Weld Neck Flange Range of Application

CLASS 2K	NPS	1 13-16"	2 1-16"	2 9-16"	3 1-8"	4 1-16"	5 1-8"	7 1-16"	9"	11"	13 5-8"	16 3-4"	
	TOOL	ATM-2											
CLASS 3K	NPS	1 13-16"	2 1-16"	2 9-16"	3 1-8"	4 1-16"	5 1-8"	7 1-16"	9"	11"	13 5-8"	16 3-4"	
	TOOL	ATM-2											
CLASS 8K	NPS	1 13-16"	2 1-16"	2 9-16"	3 1-8"	4 1-16"	5 1-8"	7 1-16"	9"	11"	13 5-8"	16 3-4"	
	TOOL	ATM-4											

### 15.3 API6B Weld Neck Flange Range of Application

CLASS 2K	NPS	2 1-16"	2 9-16"	3 1-8"	4 1-16"	5 1-8"	7 1-16"	9"	11"	13 5-8"	16 3-4"	21 1-4"	
	TOOL	ATM-2											
CLASS 3K	NPS	2 1-16"	2 9-16"	3 1-8"	4 1-16"	5 1-8"	7 1-16"	9"	11"	13 5-8"	16 3-4"	21 1-4"	
	TOOL	ATM-2											
CLASS 8K	NPS	2 1-16"	2 9-16"	3 1-8"	4 1-16"	5 1-8"	7 1-16"	9"	11"	13 5-8"	16 3-4"	21 1-4"	
	TOOL	ATM-2											



### 15.0 RANGE OF APPLICATION TABLES (Continued)

**15.4 ASME B16.5 Flange Range of Application**

CLASS 150	NPS 3/4"	1"	1 1/4"	1 1/2"	2"	2 1/2"	3"	3 1/2"	4"	5"	6"	8"	10"	12"	14"	16"	18"	20"	24"
TOOL	ATM-2																		
CLASS 300	NPS 3/4"	1"	1 1/4"	1 1/2"	2"	2 1/2"	3"	3 1/2"	4"	5"	6"	8"	10"	12"	14"	16"	18"	20"	24"
TOOL	ATM-2																		
CLASS 400	NPS 3/4"	1"	1 1/4"	1 1/2"	2"	2 1/2"	3"	3 1/2"	4"	5"	6"	8"	10"	12"	14"	16"	18"	20"	24"
TOOL	ATM-2																		
CLASS 600	NPS 3/4"	1"	1 1/4"	1 1/2"	2"	2 1/2"	3"	3 1/2"	4"	5"	6"	8"	10"	12"	14"	16"	18"	20"	24"
TOOL	ATM-2																		
CLASS 900	NPS 1/2"	3/4"	1"	1 1/4"	1 1/2"	2"	2 1/2"	3"	4"	5"	6"	8"	10"	12"	14"	16"	18"	20"	24"
TOOL	ATM-4																		
CLASS 1500	NPS 1/2"	3/4"	1"	1 1/4"	1 1/2"	2"	2 1/2"	3"	4"	5"	6"	8"	10"	12"	14"	16"	18"	20"	24"
TOOL	ATM-4																		
CLASS 2500	NPS 1/2"	3/4"	1"	1 1/4"	1 1/2"	2"	2 1/2"	3"	4"	5"	6"	8"	10"	12"	14"	16"	18"	20"	24"
TOOL	ATM-4																		

**15.6 ASME B16.47 Flange Range of Application**

CLASS 150	NPS 22"	26"	28"	30"	32"	34"	36"	38"	40"	42"	44"	46"	48"
TOOL	ATM-4												
CLASS 300	NPS 22"	26"	28"	30"	32"	34"	36"	38"	40"	42"	44"	46"	48"
TOOL	ATM-4												
CLASS 400	NPS 22"	26"	28"	30"	32"	34"	36"	38"	40"	42"	44"	46"	48"
TOOL	ATM-4												
CLASS 600	NPS 22"	26"	28"	30"	32"	34"	36"	38"	40"	42"	44"	46"	48"
TOOL	ATM-4												
CLASS 900	NPS 22"	26"	28"	30"	32"	34"	36"	38"	40"	42"	44"	46"	48"
TOOL	ATM-9												

**15.5 DIN Weld Neck Flange Range of Application**

CLASS PN16	NPS 1 1/2"	2"	2 1/2"	3"	4"	5"	6"	7"	8"	10"	12"	14"	16"	18"	20"	24"	28"	32"	36"	40"	48"	56"	72"	80"	
TOOL	ATM-2																								
CLASS PN25	NPS 1/2"	3/4"	1"	1 1/4"	1 1/2"	2"	2 1/2"	3"	4"	5"	6"	7"	8"	10"	12"	14"	16"	18"	20"	24"	28"	32"	36"	40"	
TOOL	ATM-2																								
CLASS PN40	NPS 1 1/2"	2"	2 1/2"	3"	4"	5"	6"	7"	8"	10"	12"	14"	16"	18"	20"	ATM-4									
TOOL	ATM-2																								
CLASS PN54	NPS 3/4"	1"	1 1/2"	2"	2 1/2"	3"	4"	5"	6"	7"	8"	10"	12"	14"	16"	ATM-4									
TOOL	ATM-2																								
CLASS PN100	NPS 1/2"	3/4"	1"	1 1/2"	2"	2 1/2"	3"	4"	5"	6"	7"	8"	10"	12"	14"	ATM-4									
TOOL	ATM-2																								
CLASS PN160	NPS 3/8"	1/2"	3/4"	1"	1 1/2"	2"	2 1/2"	3"	4"	5"	6"	7"	8"	10"	12"	ATM-4									
TOOL	ATM-2																								

	SUITABLE FOR ENERPAC ATM-2 TOOL
	SUITABLE FOR ENERPAC ATM-4 TOOL
	SUITABLE FOR ENERPAC ATM-9 TOOL
	NOT SUITABLE FOR ANY ENERPAC ATM TOOL

Note: Models ATM-2 and ATM-9 shown for reference purposes only.

15.0 RANGE OF APPLICATION TABLES (Continued)

15.7 SPO Flange Range of Application

CLASS 150	TOOL/NIPS 2 1/2"	3	3"	3 1/2"	4"	5"	6"	8"	10"	12"	14"	16"	18"	20"	22"	24"	26"	28"	30"	32"	34"	36"	38"	40"	42"	44"	46"	48"	
	TOOL	ATM-2																											
CLASS 300	TOOL/NIPS 2 1/2"	3	3"	3 1/2"	4"	5"	6"	8"	10"	12"	14"	16"	18"	20"	22"	24"	26"	28"	30"	32"	34"	36"	38"	40"	42"	44"	46"	48"	
	TOOL	ATM-4																											
CLASS 600	TOOL/NIPS 2 1/2"	3	3"	3 1/2"	4"	5"	6"	8"	10"	12"	14"	16"	18"	20"	22"	24"	26"	28"	30"	32"	34"	36"	38"	40"	42"	44"	46"	48"	
	TOOL	ATM-9																											
CLASS 900	TOOL/NIPS 2 1/2"	3	3"	3 1/2"	4"	5"	6"	8"	10"	12"	14"	16"	18"	20"	22"	24"	26"	28"	30"	32"	34"	36"	38"	40"	42"	44"	46"	48"	
	TOOL	ATM-4																											
CLASS 1500	TOOL/NIPS 2 1/2"	3	3"	3 1/2"	4"	5"	6"	8"	10"	12"	14"	16"	18"	20"	22"	24"	26"	28"	30"	32"	34"	36"	38"	40"	42"	44"	46"	48"	
	TOOL	ATM-9																											
CLASS 2500	TOOL/NIPS 2 1/2"	3	3"	3 1/2"	4"	5"	6"	8"	10"	12"	14"	16"	18"	20"	22"	24"													
	TOOL	ATM-9																											
CLASS 5000	TOOL/NIPS 2 1/2"	3	3"	3 1/2"	4"	5"	6"	8"	10"	12"	14"	16"	18"	20"	22"	24"													
	TOOL	ATM-4																											
CLASS 7500	TOOL/NIPS 2 1/2"	3	3"	3 1/2"	4"	5"	6"	8"	10"	12"	14"	16"	18"	20"	22"	24"													
	TOOL	ATM-9																											
CLASS 10000	TOOL/NIPS 2 1/2"	3	3"	3 1/2"	4"	5"	6"	8"	10"	12"	14"	16"	18"	20"	22"	24"													
	TOOL	ATM-9																											
CLASS 15000	TOOL/NIPS 2 1/2"	3	3"	3 1/2"	4"	5"	6"	8"	10"	12"	14"	16"	18"	20"	22"	24"													
	TOOL	ATM-4																											

	SUITABLE FOR ENERPAC ATM-2 TOOL
	SUITABLE FOR ENERPAC ATM-4 TOOL
	SUITABLE FOR ENERPAC ATM-9 TOOL
	NOT SUITABLE FOR ANY ENERPAC ATM TOOL

Note: Models ATM-2 and ATM-9 shown for reference purposes only.

## 16.0 WEIGHTS AND DIMENSIONS

**Note:** Weights shown are approximate.

### WEIGHTS

Tool with strap .....	19.2 lbs	[8,7 kg]
Torque wrench and socket .....	1.8 lbs	[0,8 kg]
Carrying case .....	14.1 lbs	[6,4 kg]
Gross weight of all items listed above .....	35.1 lbs	[15,9 kg]

### DIMENSIONS

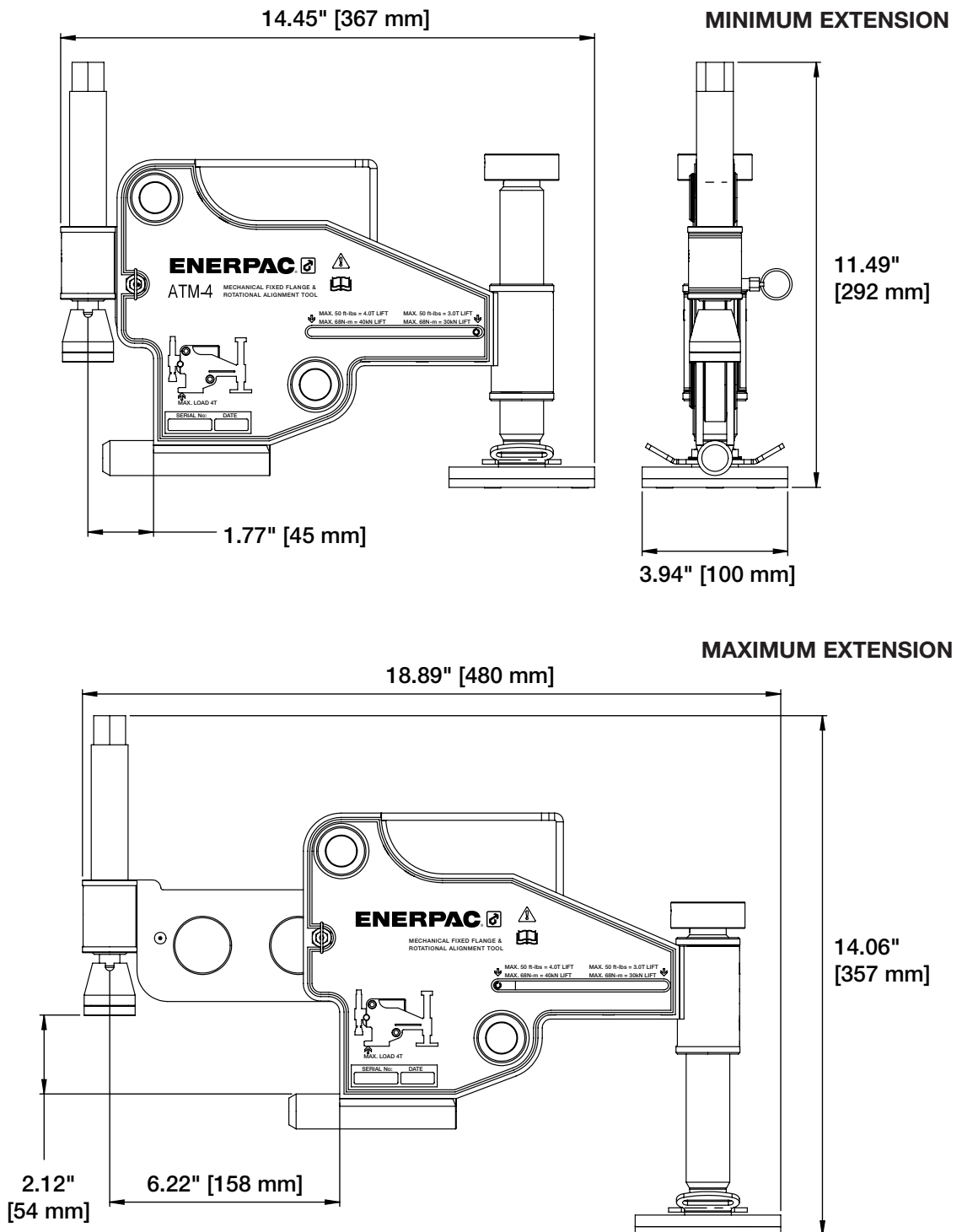

**ENERPAC** 

**TOOLS. SERVICES. SOLUTIONS.**

[www.enerpac.com](http://www.enerpac.com)