

TONE® BATTERY SHEAR WRENCH

INSTRUCTION MANUAL

NO.2105

**TO BE
PRESERVED**

MODEL

CSS60-BTL / CSS90-BTL / CSS110-BTL

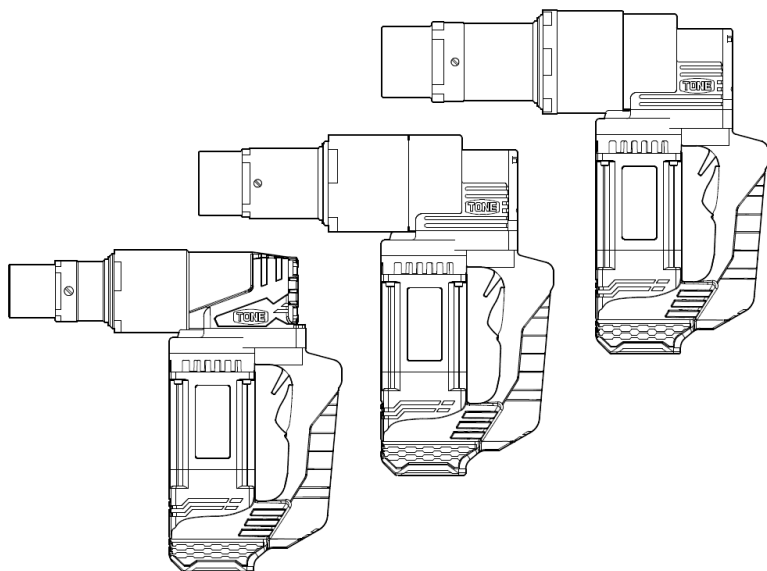

CAUTION

Read and fully understand all the instructions before use.

Keep this manual in designated place for easy and quick reference.

The models mentioned on this manual are designed for use outside Japan.

Warranty shall be void if above mentioned models are use in Japan.

TONE CO., LTD.

PREFACE

Thank you for purchasing **BATTERY SHEAR WRENCH**.

■ **Please confirm the following contents upon receipt of the product.**

- During transportation, confirming the product for any damaged parts..
- Confirming that screws and bolts have not dropped and loosened in any part of the product.
- Confirming that the product is the model number/specification as ordered
- Confirming that all accessories are completed. (⇒P. 16).

If there are any problems, please contact the distributor where you purchased the product.

■ **Read this instruction manual carefully before use.**

A full understanding of the manual is essential to prevent personal injury or malfunction.

■ **Keep this manual in a bag attached to the back of the metal case lid for easy and quick reference.**

■ **If the manual or warning label is lost or becomes illegible, or if an additional manual is required, please contact the distributor where you purchased the product.**

If you have any questions about the product you have purchased or the contents of the instruction manual, please contact the distributor where you purchased the product.



■ **This manual is only applicable outside Japan.**

SAFETY INSTRUCTION

This manual specifies three (3) basic safety instructions:



■ Instructions are classified by degree of risk and described as follows:

	Danger is used to indicate threatening dangerous or unsafe practices which could immediately result in severe personal injury or death in the worst case.
	Warning is used to indicate hazardous or unsafe practices which could result in severe personal injury or death in the worst occasion.
	Caution is used to indicate hazardous or unsafe practices which could result in personal injury or product or property damage.

Even if the risk is classified as  , risk could become more serious result depending on conditions. Make sure to follow all instructions when using.

TABLE OF CONTENTS

1. GENERAL SAFETY INSTRUCTIONS	5
2. APPLICATION	8
3.  PRECAUTIONS FOR USE	8
4. NAME OF PARTS AND ACCESSORIES.....	16
5. BEFORE USE	17
6. PRECAUTIONS FOR USE LITHIUM-ION BATTERIES	18
7. INSTALLATION/REMOVAL OF STORAGE BATTERY	22
8. REMAINING BATTERY LEVEL.....	23
9. PRECAUTIONS FOR WORK.....	24
10. OPERATING PROCEDURE	24
11. SOCKET REPLACEMENT.....	26
12. INSPECTION & MAINTENANCE	28

<u>13. TRANSPORTATION OF LITHIUM-ION BATTERIES</u>	<u>30</u>
<u>14. STORAGE OF LITHIUM-ION BATTERIES</u> ...	<u>31</u>
<u>15. FAILURE DIAGNOSIS</u>	<u>32</u>
<u>16. FEATURES</u>	<u>32</u>
<u>17. SPECIFICATIONS</u>	<u>33</u>
<u>18. AFTERSALES SERVICE</u>	<u>34</u>

1. GENERAL SAFETY INSTRUCTIONS



WARNING

When using electric tools, basic safety precautions, including the following, should always be followed to reduce the risk of fire, electric shock and personal injury. Read all these instructions before operating this product and keep these instructions.

SAVE THESE INSTRUCTIONS

1) Work area

- a) Keep work area clean and well lit. Cluttered and dark areas invite accidents.
- b) Do not operate power tools in explosive atmospheres, such as in the presence of flammable liquids, gases or dust. Power tools create sparks which may ignite the dust or fumes.
- c) Keep children and bystanders away while operating a power tool. Distractions can cause you to lose control.

2) Electrical safety

- a) Power tool plugs must match the outlet. Never modify the plug in any way. Do not use any adapter plugs with earthed (grounded) power tools. Unmodified plugs and matching outlets will reduce risk of electric shock.
- b) Avoid body contact with earthed or grounded surfaces such as pipes, radiators, ranges and refrigerators. There is an increased risk of electric shock if your body is earthed or grounded.
- c) Do not expose power tools to rain or wet conditions. Water entering a power tool will increase the risk of electric shock.

3) Personal safety

- a) Stay alert, watch what you are doing and use common sense when operating a power tool. Do not use a power tool while you are tired or under the influence of drugs, alcohol or medication.
A moment of inattention while operating power tools may result in serious personal injury.
- b) Use safety equipment. Always wear eye protection. Safety equipment such as dust mask, non-skid safety shoes, hard hat, or hearing protection used for appropriate conditions will reduce personal injuries.
- c) Avoid accidental starting. Ensure the switch is in the off position before plugging in. Carrying power tools with your finger on the switch or plugging in power tools that have the switch on invites accidents.
- d) Remove any adjusting key or wrench before turning the power tool on. A wrench or a key left attached to a rotating part of the power tool may result in personal injury.
- e) Do not overreach. Keep proper footing and balance at all times. This enables better control of the power tool in unexpected situations.
- f) Dress properly. Do not wear loose clothing or jewelry. Keep your hair, clothing and gloves away from moving parts. Loose clothes, jewelry or long hair can be caught in moving parts.
- g) If devices are provided for the connection of dust extraction and collection facilities, ensure these are connected and properly used. Use of these devices can reduce dust related hazards.

4) Power tool use and care

- a) Do not force the power tool. Use the correct power tool for your application. The correct power tool will do the job better and safer at the rate for which it was designed.
- b) Do not use the power tool if the switch does not turn it on and off. Any power tool that cannot be controlled with the switch is dangerous and must be repaired.
- c) Disconnect the plug from the power source before making any adjustments, changing accessories, or storing power tools. Such preventive safety measures reduce the risk of starting the power tool accidentally.
- d) Store idle power tools out of the reach of children and do not allow persons unfamiliar with the power tool or these instructions to operate the power tool. Power tools are dangerous in the hands of untrained users.
- e) Maintain power tools. Check for misalignment or binding of moving parts, breakage of parts and any other condition that may affect the power tools operation. If damaged, have the power tool repaired before use. Many accidents are caused by poorly maintained power tools.
- f) Use the power tool, accessories and tool bits etc., in accordance with these instructions and in the manner intended for the particular type of power tool, taking into account the working conditions and the work to be performed. Use of the power tool for operations different from intended could result in a hazardous situation.

5) Service

- a) Have your power tool serviced by a qualified repair person using only identical replacement parts. This will ensure that the safety of the power tool is maintained.

2. APPLICATION

- **BATTERY SHEAR WRENCH** is an electric tool for tightening Tension Control Bolt/Nut/Washer assemblies.

3. PRECAUTIONS FOR USE

- To prevent accidents, personal injury, etc., read and follow all instructions listed below.
- We are not responsible for any accidents caused by using this product on applications not written on this manual.
- If non-genuine parts are used for this product, it will be judged as a modified product and all warranties will be invalidating.

DANGER

- **Beware of electric shock when operating at the high place.**
 - Failure to follow this instruction may result in fall down accidents.

WARNING

- **Beware of electric shock.**
 - Never use the wrench under rainy or snowy conditions.
 - Never touch the charger plug with wet hands.

Failure to follow this instruction may result in electric shock, fire, or electric leakage.
- **Never use the wrench around the place where gasoline, gas, thinner, benzene, etc., are stored.**
 - Do not use the wrench around flammable substances. It may cause an explosion or fire.

 **WARNING**

● **Beware of fall down accidents when working at a high place.**

- Wear safety belt
- Provide safety net or canvas as safeguarding against falling items.
- Confirm that no one is underneath the working site before operation.
- Stop operation when physically or mentally tired.

Failure to follow these instructions may result in fall down accidents.

● **Avoid overloading.**

- Use the wrench and its accessories within the rated specifications.

Overloaded wrench and its accessories may result in a malfunction of the wrenches, accidents, or personal injury.

● **Properly install sockets as described in this manual.**

- Incomplete installation may result in accidents and personal injury.
See “SOCKET REPLACEMENT” on page 26.

● **Avoid accidental starting.**

- Do not put your finger on the switch when carrying the wrench with the storage battery installed.
- Before inserting the storage battery, make sure that the switch is turned off. It may start up accidentally and may cause injury.

 **WARNING**

● **Remove the storage battery from the wrench when:**

- Not in use.
- Changing accessories.
- Inspection and maintenance.
- Or another danger is foreseen.

Failure to follow these instructions may result in accidental starting and personal injury.

● **Do not disassemble or modify the wrench.**

- Disassembly or modification made by unauthorized personnel may result in malfunction or personal injury.
- Disassembly & Re-assembly work is permitted for the following expendables: inner socket, outer socket, set screws, inner socket spring, ejector pin, ejector spring, and storage battery.

● **Store wrench in the metal case and keep it at the designated place when not in use.**

- Store wrench in a lockable dry location to keep any unauthorized personnel away.

Failure to follow this instruction may result in malfunction or accidents.

Do not store the wrench or storage battery in a place where the temperature may rise above 50 ° C (such as a metal box or a car in the summer).

It may cause deterioration of the storage battery and cause smoke and fire.

 **WARNING**

- **Immediately stop using the wrench and turn off the switch when unusual sound, vibration, or smell is detected.**

- Contact your distributor immediately.

Failure to follow this instruction may result in serious injury.

- **Contact your distributor for repair service.**

- Repair work should only be carried out by a qualified serviceman.

- Repair work done by an inexperienced person may cause accidents, injury or malfunction.

- **Check the following items before operation.**

- Check for any deformation, crack or damage on the wrench body, sockets, electric cord, plug and etc.

- Do not use the wrench if any problem are found on items listed above.

- Make sure that socket assembly is correctly installed on the wrench.

- Make sure that set screws are securely fastened. Loose installation may result in accidents and personal injury.

- **Immediately check the wrench when it is dropped down or banged.**

- Check for deformation, crack, damage and other abnormality. Stop using the wrench if any abnormality is found.

Continued use of fault wrench may result in accidents and personal injury.

 **WARNING**

● **Use the specified storage battery and charger.**

- Do not use modified storage batteries (including storage batteries that have been disassembled and replaced with internal parts such as cells).

There is a risk that the performance and safety of the wrench will be impaired.

It may cause injury, malfunction, smoke, heat generation, ignition, explosion, etc.

● **Do not put the storage battery in a fire or heat it.**

It may cause overheating, ignition or explosion.

● **Do not pierce the storage battery with nails, give it impacts, or disassemble or modify it.**

It may cause overheating, ignition or explosion.

● **Do not short-circuit the terminals of the storage battery.**

- Do not store the storage battery together with metal in a toolbox or nail bag.

It may cause overheating, ignition or explosion.

- After removing the storage battery from the wrench body or the charger, be sure to attach the battery cover to the storage battery.

● **Do not charge, use or store the storage battery in a hot place such as near a fire or under the scorching sun.**

It may cause liquid leakage, heat generation, or explosion of the storage battery.

● **Do not put a conductive liquid such as water inside the storage battery.**

It may cause overheating, ignition or explosion.

 **WARNING**

● **Consider the surrounding conditions of the workplace and storage location.**

- Do not use the wrench body, charger, or storage battery in the rain or a damp place, or leave or store it.

It may cause electric shock or smoke.

● **Do not use a storage battery whose usage time is extremely short.**

● **Do not use a battery that has been dropped or damaged in any way.**

● **There is a risk of fire. Do not do the following:**

- Do not charge on paper such as cardboard, cloth such as cushions, tatami mats, carpets, vinyl, etc.
- Do not allow anything to cover or clog the charger vents.
- Do not charge in a dusty place such as cotton dust.

● **Do not use if the wrench body or the terminal of the storage battery (storage battery mounting part) is deformed.**

If a storage battery is installed, it may short-circuit and cause smoke or fire.

● **Make sure that chips and dust do not collect on the terminal of the wrench body (battery mounting part).**

- Before use, make sure that the terminals are free of chips and dust.
- During work, make sure that chips and dust on the wrench do not fall on the terminals.
- Do not leave the wrench body in a place where chips and dust will fall during and after use.

It may cause a short circuit and cause smoke or fire.

 **CAUTION**

● **Make sure to install the storage battery securely.**

If it is not installed securely, the storage battery may come off and cause injury.

● **Do not dispose of the storage battery with ordinary garbage or put it in a fire**

● **Keep the storage battery out of the reach of children.**

● **Use the battery correctly according to the specifications displayed.**

● **Keep work area clean.**

- Cluttered areas and benches invite accidents.

● **Keep children away.**

- Do not let children touch the wrench and electric cord.
- All visitors should be kept away from work area.

● **Secure work area.**

- Keep body stance balanced and firmed.
- Keep work area well lit.

● **Use the suitable model for each application.**

- Do not use wrench beyond its rated specifications.
- Do not use wrench for purpose not intended.

 **CAUTION**

● **Please dress properly for your work.**

- When working outdoors, use rubber gloves and non-slip footwear.
- Please wear a helmet, hat, etc. properly when entering the work site..

● **Use genuine accessories and attachments manufactured by TONE CO., Ltd.**

Give good ventilation of the motor.

- Do not insert any objects into the ventilation port of the motor.
- Do not cover the air vent of the motor with anything.

● **If the battery fluid gets into your eyes, immediately wash your eyes thoroughly with clean water and seek medical attention.**

● **Please clean the wrench properly and carefully.**

When using, keep the grip dry at all times to prevent oil and grease from getting on them.

● **Observe local laws and rules concerning noise level.**

● **If you notice any abnormalities such as heat generation during charging, immediately disconnect the power plug and stop charging.**

Continuing to charge the battery may cause smoke, fire, or explosion.

4. PART NAME

(Figure 1)

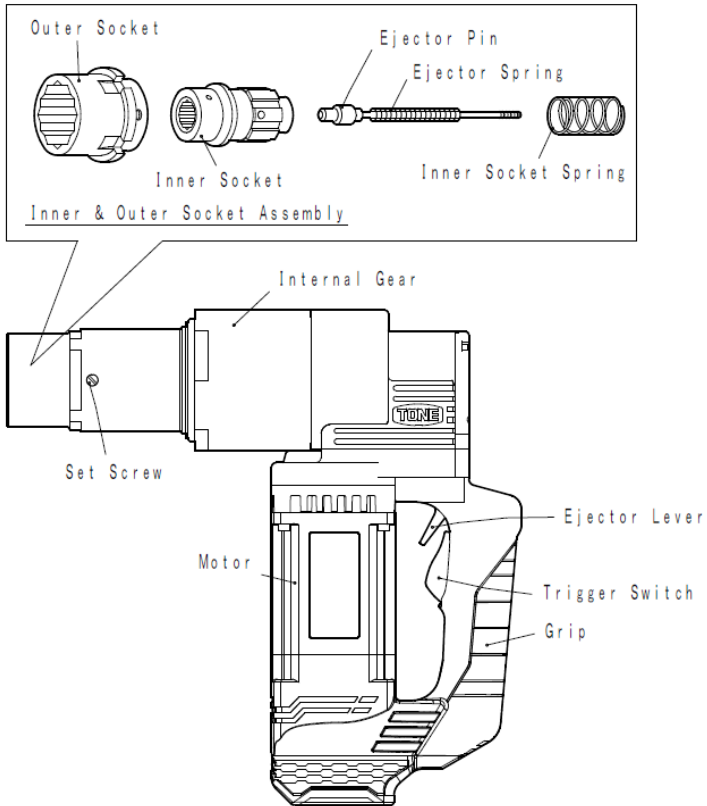

MODEL	ACCESSORIES
CSS60-BTL	Inner Socket
CSS90-BTL	Outer Socket
CSS110-BTL	Inner Socket Spring
	Ejector Pin
	Ejector Spring
	Screwdriver (-)
	Instruction Manual

- Contact your distributor for other available sockets and accessories.

5. BEFORE USE



WARNING

● **Please check followings before use.**

It may cause injury.

1. Check for any deformation, crack or damage on wrench body, socket, storage battery, charger, parts, etc.

Do not use wrench if any problem is found on items listed above.

2. Please check the power supply.

Use the power supply indicated on the nameplate of the charger.

3. Select the socket according to the size of the bolt/nut to be tightened.

4. Make sure that socket assembly is correctly installed on the wrench.

Make sure that set screws are securely fastened.

Loose installation may result in accidents and personal injury.

See “SOCKET REPLACEMENT” on page 26.

6.PRECAUTIONS WHEN USE LITHIUM-ION BATTERIES

While using this product, the motor may stop in the following cases (1), (2), and (3) even if the switch is pulled, but this is due to the protection function and is not a malfunction.

(1) The motor will stop when the battery level is low. In this case, charge the battery immediately.

(2) If the wrench body becomes overloaded, the motor may stop. In this case, release the switch once to eliminate the cause of the overload.

(3) If the storage battery becomes overheated, the motor may stop. In this case, stop using the storage battery, remove it from the wrench body, and cool the storage battery sufficiently with a well-ventilated shade.

Then it can be used again.

In addition, be sure to observe the precautions below to prevent leakage, heat generation, smoke, and ignition of the storage battery.



WARNING

- **Use a dedicated charger and storage battery.**

If a storage battery other than the specified one is used, it may explode and cause injury or damage.

- **Charge properly.**

- Do not charge the storage battery outside the operating temperature range of the charger.

Not only will it not be charged properly, but the life of the battery will be shortened. In addition, there is a risk of explosion and fire.

- Charge the storage battery in a well-ventilated place.
- Do not cover the storage battery or charger with a cloth while charging.

There is a risk of explosion or fire.

- **Do not short-circuit the terminals of the storage battery.**

If you put it in a nail bag, it may cause a short circuit, resulting in smoke, fire, or explosion.

- **Do not put a conductive liquid such as water inside the storage battery.**

There is a risk of overheating, ignition, and explosion.

- **Do not put the storage battery in a fire.**

It may explode or emit harmful substances.

- **Do not put the storage battery in a fire.**

It may explode or emit harmful substances.

 **WARNING**

- **Be sure to observe the following to prevent battery leakage, heat generation, smoke, and ignition.**
- **Make sure that chips and dust do not collect on the storage battery.**
 - Make sure that chips and dust on the wrench do not fall on the storage battery during work.
 - Do not leave the storage battery in a place where chips and dust fall when not in use.
 - When storing, remove chips and dust from the storage battery and keep it separate from metal parts (screws, nails, etc.).
- **Do not give a strong impact such as put a nail in the storage battery, hit it with a hammer, step on it, or throw it.**
- **Do not use a storage battery that is significantly damaged or deformed.**
- **Do not use (+) and (-) in reverse.**
- **Do not connect the battery directly to an outlet or a car cigarette outlet.**
- **Do not use the storage battery for any purpose other than the designated equipment.**
- **Do not overheat or apply high pressure, such as putting the storage battery in a microwave oven or a high-pressure container.**
- **If the storage battery leaks or smells bad, keep it away from fire immediately.**

 **WARNING**

- If you notice a strange odor, heat generation, discoloration, deformation, or other abnormalities when using, charging, or storing the storage battery, stop using it immediately and contact the distributor where you purchased the product.

 **CAUTION**

- If the storage battery leaks and gets into your eyes, immediately wash your eyes with clean water such as tap water without rubbing, and then seek medical attention immediately.

If left untreated, the liquid may damage your eyes.

- If the storage battery leaks and the liquid adheres to your skin or clothing, immediately wash it off with clean water.

It may cause a rash on the skin.

Storage batteries for recycling

Batteries are a valuable recyclable resource. When disposing of storage batteries or products, please cooperate with recycling and bring them to the distributor where you purchased the product.



7. INSTALLATION / REMOVAL OF STORAGE BATTERY

- When removing the storage battery from the wrench body, slide it while pressing the latches on both sides
- When attaching the storage battery to the wrench body, align it with the groove on the wrench body and insert it completely until you hear a click.

8. PRECAUTIONS FOR OPERATION

- About continuous use

The cordless shear wrench is equipped with a temperature protection circuit to protect the motor and the electronic components that control the drive of the motor.

If you use it continuously, the temperature of the wrench will rise, so the temperature protection circuit will operate and may stop automatically. In that case, cool the wrench sufficiently. It can be used again when the temperature drops.

Also, when working continuously, rest the wrench for about 15 minutes when replacing the storage battery before using it.

9. OPERATING PROCEDURE

CAUTION

- Snug tight using snug tightening wrench like SNUG MASTER is required before using SHEAR WRENCH.

(1) Slide Inner Socket over the bolt pintail (Figure 2).

(Figure 2)

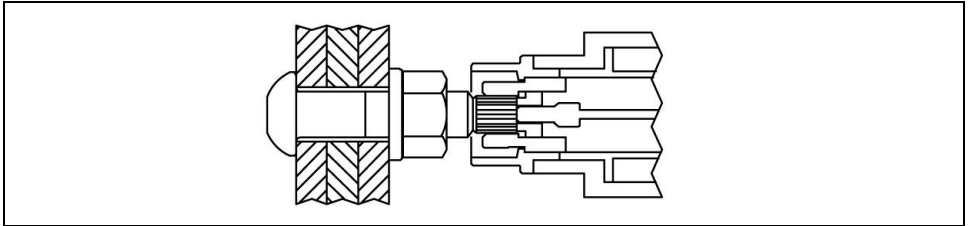

(2) Slide Outer Socket over the nut (Figure 3).

- Slightly turn Internal Gear when slide over is difficult.
- Outer Socket can not be engaged on the nut when Anti defacement mechanism of the Inner Socket detects improper Inner Socket engagement. In such case, back to step (1) and slide the Inner Socket completely.

(Figure 3)

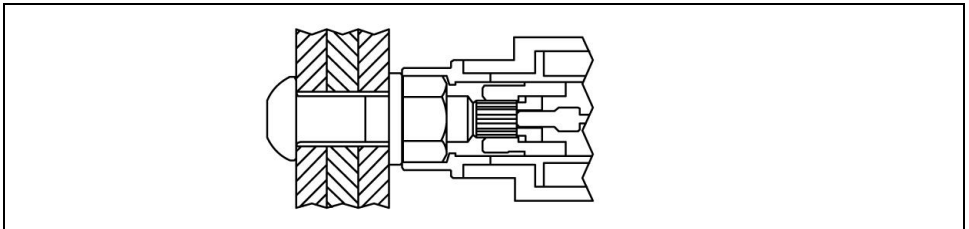

(3) Squeeze trigger switch to start tightening (Figure 4).

(Figure 4)

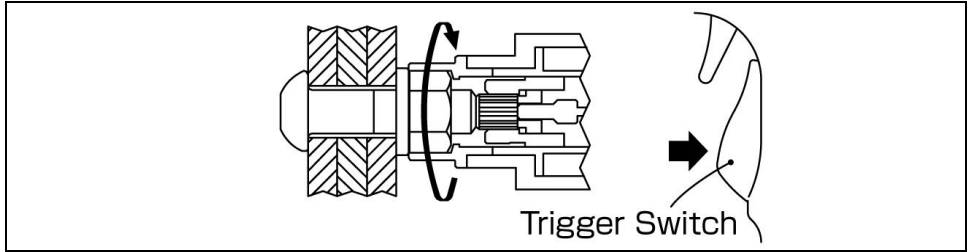

(4) Rotating speed gradually shows down as the tightening proceeds, then bolt pintail shears off when designated torque is reached (Figure 5).

(Figure 5)

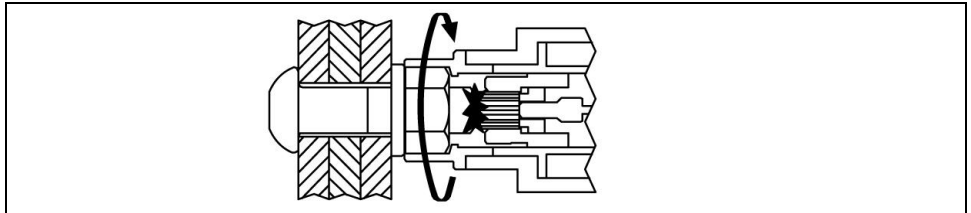

(5) When tightening is completed, remove wrench from bolt/nut assembly. Sheared-off bolt pintail remains in Inner Socket (Figure 6).

(Figure 6)

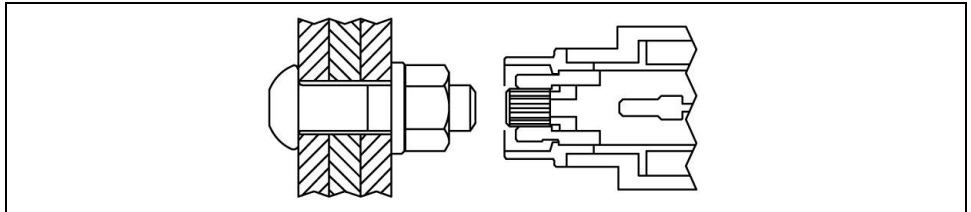

(6) Pull Ejector Lever to eject bolt pintail (Figure 7).
Keep pintail in designated bag.

(Figure 7)

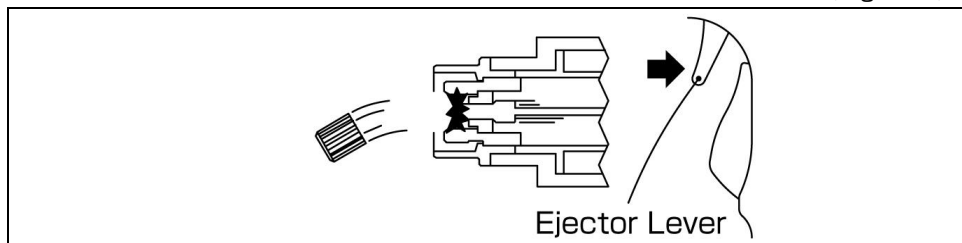

⚠ WARNING

● **Keep others a safe distance from work area.**

- Do not throw pintail away. Collect pintail in designate bag during operation.

Failure to follow this instruction may result in accidents and personal injury.

10. SOCKET REPLACEMENT

WARNING

- **Release ejector pin by pulling ejector lever before changing sockets.**

Accidental ejector pin release invites blindness or injury.

- (1) Remove inner & outer socket assembly from wrench by unscrewing set screws (Figure 8). Do not remove set screws completely from outer socket holder.

(Figure 8)

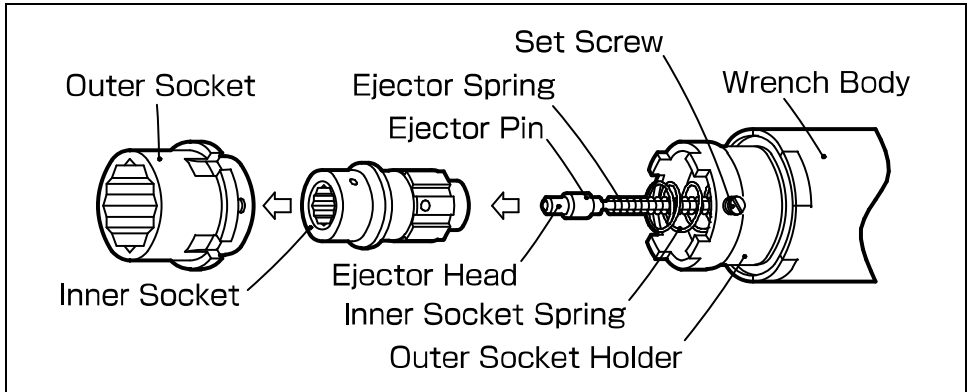

- (2) Prepare outer and inner-sockets of the right sizes suitable for the size of bolt to be tightened.
...Example : Use our standard socket for 3/4" to 3/4" bolts.

(3) As per (Figure 9), firstly install inner socket onto ejector-pin on the main body and then, install outer-socket into inner-socket.

(Figure 9)

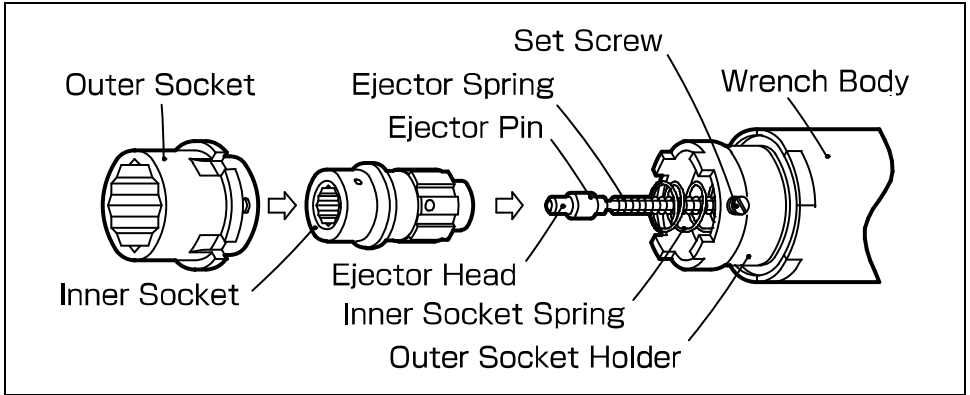

(4) There might be the case that perfect installation is not obtainable due to a gap between main body and outer-socket, as shown per (Figure 10).

(Figure 10)

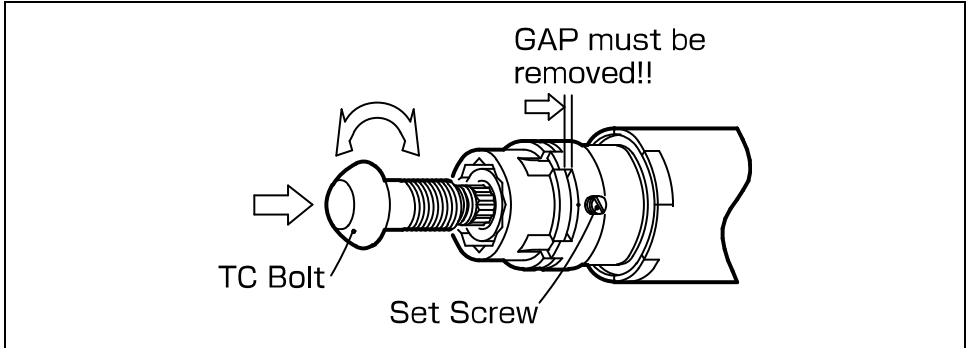

WARNING

- There should be no gap between the socket assembly and the wrench.

The gap invites accidents or breakage of the sockets or the wrench body.

11. INSPECTION & MAINTENANCE



WARNING

- Turn off the switch and remove the storage battery from the wrench. Also, remove the power plug from the outlet of the charger before inspection and maintenance.
- Accidental starting invites serious injury.



WARNING

- **Replace the inner socket when sheared bolt pintail is coming off the inner socket without pulling the ejector lever.**
 - There is a risk of unexpected bolt pintail ejection when inner drive of the inner socket is worn down. The inner socket must be immediately replaced.
- Failure to follow this instruction may result in serious accidents and injury.



CAUTION

- **If there are chips or dust on the terminals, remove them.**
 - Continuing to use it may cause a malfunction.

- Check the terminals for chips and dust. Check from time to time before and after work as well as during work.
- Clean dust and debris from the sockets periodically.
- Use only a dry cloth to clean your wrench and sockets since organic solvents such as benzene, thinner and gasoline may cause cracks or discoloration to those parts.
- Be careful not to let oil and organic solvents get inside the motor.
- Store wrench in the metal case after operation and keep it dry.
- Ejector pin must be regularly inspected and replaced when it wears down. Sheared bolt pintail will not be ejected from inner socket with worn ejector pin.
- Overhaul must be carried out every 6 months or 30,000 tightening, whichever comes first. Contact your distributor for overhaul.

12. TRANSPORTATION OF LITHIUM-ION BATTERIES

- When transporting lithium-ion batteries, please heed the following points.



WARNING

- **Please inform the carrier that the package contains lithium-ion batteries and the battery capacity, and follow the instructions of the carrier.**
 - Lithium-ion batteries' energy capacity exceeding 100Wh will be treated as dangerous goods in terms of the classification of transported cargo, and a special application form will be required.
 - When transporting overseas, it is necessary to comply with international regulations and the regulations of the destination country.

13. STORAGE OF LITHIUM-ION BATTERIES



WARNING

● If a conductive object gets into the terminal of the lithium-ion battery, the battery may be shorted, causing heat generation, smoke, or ignition. Therefore, be sure to obey the following when storing.

- Do not put conductive chips, nails, wires, copper wires, or other wires in the storage case.
- To prevent shorting from occurring, load the battery in the wrench body or insert the battery cover securely for storing until the ventilator is not visible.



CAUTION

● Fully charge the lithium-ion battery before storing it.

- If the storage battery is stored for a long time (3 months or more) with low remaining capacity, the storage battery may deteriorate, the usage time may be significantly shortened, or the battery may not be charged. Even if the storage battery's usage time is significantly reduced, it may be restored by repeating charging and use 2 to 5 times. If the usage time is extremely short even after repeated charging and use, it may indicate the end of the battery life, and we recommend you purchase a new battery.

14.FAILURE DIAGNOSIS

If "Failure diagnosis" does not work, please contact the distributor where you purchased the product.

Also, it may cause by the storage battery, so please bring the charger and storage battery together.

■Wrench body

Failure symptoms	Cause	How to deal
Pulling the switch does not start	Battery is low	Storage batteries need to be recharged
Wrench shutdown	Battery is low	Please charge the battery.
	Overloaded during tightening	The motor will automatically stop when the wrench overloaded. Check the tightening status and eliminate the cause of overload.
	The storage battery or wrench body has become overheated	Cooldown the storage battery and the wrench body sufficiently.

15.FEATURES

- New DC brushless motor is used.
- With remaining storage capacity display
- With anti-defacement mechanism
- Common use of S series socket

16.SPECIFICATIONS

■ Wrench Body

Model	Motor	Storage Battery	No-load rpm (min ⁻¹)	Weight (kg)
CSS60-BTL	DC brushless motor	DC 36V	19	6.0
CSS90-BTL	DC brushless motor	DC 36V	10	7.4
CSS110-BTL	DC brushless motor	DC 36V	7	7.9

● Weight excludes socket.

Model	Adaptable Bolt Dia		Dimensions(mm)	
	A325	A490	Gear Diameter	Length × Height × Width
CSS60-BTL	7/8", 3/4", 5/8"	3/4", 5/8"	φ73	241 × 340 × 90
CSS90-BTL	1", 7/8", 3/4", 5/8"	1", 7/8", 3/4", 5/8"	φ85	313 × 354 × 90
CSS110-BTL	1-1/8", 1" 7/8", 3/4"	1-1/8", 1" 7/8", 3/4"	φ92	341 × 354 × 90

Model	Approximate number of tightening per full-charged battery(4.0Ah)
CSS60-BTL	Approx.240 pcs .※When tightening 7/8" TC Bolt(A325)
CSS90-BTL	Approx.150 pcs .※When tightening 1" TC Bolt(A325)
CSS110-BTL	Approx.150 pcs .※When tightening 1-1/8" TC Bolt(A325)

17. AFTER SALES SERVICE

Contact your distributor for available services.

Provide model, serial number, date of purchase and details of failure when contacting your distributor.



CAUTION

- **Do not use wrench when malfunction, deficiency in wrenches' performance, personal injury or property loss is foreseen.**

If possible, prepare backup wrenches beforehand.

TONE[®] TONE CO., LTD.



1-57, MINATOMACHI 2-CHOME, NANIWA-KU,
OSAKA 556-0017, JAPAN,

Web Site: <http://www.tonetool.co.jp>

e-mail: overseas@tonetool.co.jp

● Specifications and the design are subject to change without notice. ●